

Interactivity in Terrestrial DTV Systems: the DVB-RCT Standard[♦]

Ângelo Pinelli Martins Samia e Dayan Adionel Guimarães

National Institute of Telecommunications – Inatel
P.O. Box 05 – 37540-000 Santa Rita do Sapucaí – MG – Brazil

Abstract— The use of terrestrial broadcast digital TV platform to increase the percentage of the population with access to the Internet is conditioned to the implementation of a bi-directional link between the user and the broadcaster. One of the alternatives for the return channel is the DVB-RCT (Digital Video Broadcasting Return Channel – Terrestrial) standard, which suggests the use of a wireless return path in the VHF/UHF bands. This standard has been designed to operate with a DVB-T broadcast channel. This work is a tutorial about the DVB-RCT standard, incorporating the main features of the physical layer and issues like capacity and suitability for implementation in Brazil.

Index Terms—interactivity, digital TV systems, DVB-RCT, terrestrial broadcast, OFDMA multiple access.

I. INTRODUCTION

The digital TV (DTV) signal allows processing techniques that substantially improve the quality of the received signal and greatly increase the number of services that can be offered to users. The degree of content manipulation provided by DTV systems is practically impossible to be achieved using analog technology. Once digitized, the video and audio signals are compressed and can be multiplexed with data from other video, audio or from an application that establishes, for instance, an IP session between the broadcaster and the set-top box. Depending on the resolution of the picture, up to five programs¹ can be conveyed in a portion of the spectrum previously assigned to only one analog channel. This convergence is a benefit that comes along with technology and tends to change the way people watch TV in the near future. The degree of interactivity experienced by the user depends on what kind of service is being offered by the broadcaster. In some cases there is only *local* interactivity between the user and the set-top. It takes place, for example, in applications like Electronic Program Guides (EPG) and some games, where there is no need for the user to transmit information towards the broadcasting site. When a link is established from the user to the broadcaster, the so-called *return channel*, a higher degree of interactivity is possible and the user is able to participate in polls, to purchase products using the remote

control, to buy pay-per-view events or to surf the internet.

Currently, the main focus of discussion about digital TV in Brazil is the transmission standard for terrestrial broadcasting, and the Government has been supporting the idea of developing its own standard. Decree number 4,901 was issued in November, 2003 and instituted the SBTVD (acronym for Brazilian Digital Television System), whose objectives, among others, are to promote social inclusion, to stimulate in-country research and development (R&D), and to motivate the production of interactive content by current analog TV broadcasters [1]. SBTVD is composed by: a Committee of Development, associated to the Presidency, an Advisory Committee, and a Management Group. In a letter sent to the President of Brazil in November, 2003 [2], in which the approval of decree N° 4,901 is requested, former Minister of Communications Miro Teixeira sustained the idea that the system to be adopted should “provide interactivity and allow for the development of new applications that deliver entertainment to the population, promote the culture and improve education and citizenship”. In the same document, Teixeira complements: “The research and development of a Brazilian system intends to find solutions that are suitable to our social and economical realities, without necessarily excluding, *a priori*, the possibility of *choosing any of the foreign systems currently available, provided that they are in line with the Brazil’s social and financial interests*”.

During the opening of Telexpo 2004, Minister of Communications Eunício de Oliveira pointed out the attention the Government has been dedicating to implementing DTV systems in Brazil. Several institutions bid for the contracts to construct solutions for the physical, transport, middleware and application layers of the system; some of these institutions had started working on their projects at the time of this publication.

In order for the DTV platform to reach the purposes of the so-called digital inclusion, it is desirable that the system is two-way capable. In this context, the main objective of this work is to outline the recommendation for wireless return channel in terrestrial broadcasting networks, developed by the technical subgroup Digital Video Broadcasting Return Channel - Terrestrial (DVB-RCT) [3] and standardized in Europe by the European Telecommunications Standards Institute (ETSI) in March, 2002. Given this moment of critical definitions about which DTV system will be adopted in Brazil, another objective of this work, not less important than the first one, is to foment the discussions about a basic

[♦]This work has been partially financed by convention n° 22.02.0431.00 between Inatel, Linear Equipamentos Eletrônicos S/A and FINEP (Financiadora de Estudos e Projetos).

¹ The term *program* has the same meaning as *channel* for the analog PAL-M or NTSC systems (i.e., Globo, CNN, HBO etc.).

requirement to offer interactive services in DTV networks: the *return channel*.

A set-top box equipped with a DVB-RCT return module is able to transmit information back to the base-station using the same antenna of the broadcast signal reception. Although, DVB-RCT was originally designed to work with DVB-T (Digital Video Broadcasting–Terrestrial)[4], the operation with Advanced Television Systems Committee (ATSC) is suggested in [5]. However, the Radio-frequency Standardization Section of International Telecommunications Union (ITU-R) recommends the use of “the DVB-RCT system as the preferred wireless return path for the DVB-T Digital Terrestrial TV Systems”.

The set-top box will play an important role during the transition from the analog to the digital technology. The hardware architecture of these devices is similar to the personal computers (PCs), and likewise, the more sophisticated the set-top is the more it will cost. The hardware must comply with the needs of compatibility and processing required by each application. For example, some models are equipped with hard disks with up to 160 GB [6] of capacity for applications like personal video recording (PVR). Like the PCs, the set-tops also need an operating system (OS). Because the hardware resources are limited in the set-top box, the architecture of the OS is different from the ones designed for the PCs. Power TV OS, Microsoft Windows CE and some versions of Linux are examples of operating systems specifically designed to work with the set-top box. The smart-card technology can provide flexibility on the distribution of purchasable content and the return-channel module may be optional. It is possible to realize, through these examples, the advantages of a platform that is modular and standardized, in such a way that several manufacturers can compete against each other with the consumer getting the pricing benefits that arise from competition.

The president of ANATEL (the Brazilian National Telecommunications Agency), Pedro Jaime Ziller de Araújo, asserted [7] that there is an estimated market of US\$ 1.95 billion only to adapt the existing 65 million TV sets to the digital technology. To arrive at this number, Ziller de Araújo assumed that at least 60% of the users would buy the set-top box at an approximated price of US\$ 50. The president of the agency added that, at broadcasters’ side, the investment in digital equipment would be around US\$ 1.5 billion. The major challenge, still, is to use the technology to envisage new ways to increase revenue, keeping in mind the objective of democratizing the access to information technology.

This remainder of this article is organized as follows: Section II covers the building blocks of a conventional digital TV broadcasting site. Section III deals with possible DTV architectures with interactivity features. Section IV presents the wireless return channel based on DVB-RCT standard, with focus on the two types of channel coding supported by this standard and on the multiple access technique OFDMA (Orthogonal Frequency Division Multiple Access). In section V, the

cellular structure of the wireless interactive system is shortly described, and in section VI a case study is presented. Section VII concludes with some final remarks and in Section VIII a glossary of abbreviations aims at facilitating the reading.

II. DIGITAL TV SYSTEMS

DTV systems will allow the user to improve their viewing experience through cinema-quality pictures, CD-quality sound, more channels and improved access to a range of new entertainment services. Figure 1 depicts an architecture model for a DTV system.

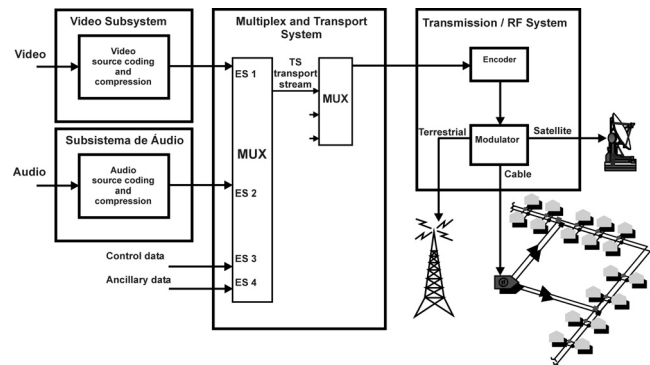

Figure 1 - Basic architecture of a DTV system

According to the model shown in Figure 1, a digital TV system can be split into three subsystems: (i) coding and compression subsystem, which reduces the bandwidth occupied by the digitized audio and video signals by means of source coding [8 pp. 568-580]; (ii) multiplex and transport subsystem, which refer to the means of dividing the digital data stream into packets of information, the means of uniquely identifying each packet or packet type, the appropriate methods of multiplexing video data-stream packets, audio data stream packets, and ancillary data-stream packets into a single transport stream (TS) [9] [10], and the mechanisms for one more level of multiplexing, the system level, where individual program transport streams are combined; (iii) the Transmission / RF stage, where the techniques used for channel coding and modulation vary according to the way the signal is broadcast (i.e., terrestrial broadcast, cable or satellite). The return channel is not represented in Figure 1 and will be covered in Section III.

II.1 SOURCE CODING AND COMPRESSION SUBSYSTEM

The source coding and compression subsystem use the appropriate methods to process the video and audio signals. These methods must take into consideration the particularities of each type of signal, and the kind of redundancy they may have. Therefore, compacting a signal consists of removing as much as possible its redundancy without losing any information. In cases like the video signal, it is acceptable that *there is* loss of information, in which situation the process is called compression. In order to have an idea on how important video compression is, suppose that frames with 1,080 lines and 1,920 pixels per line are transmitted at a rate of

30 frames per second. If each pixel is represented by three component colors with 8 bits each, the required transmission rate will be $R = 1.080 \times 1.920 \times 30 \times 3 \times 8 \cong 1.5$ Gbit/s. It is not practical to convey such a rate through a 6 MHz channel with the existing modulation and channel coding methods.

The redundancy in a video signal can be spatial, as happens when adjacent pixels have little or no variation; or temporal, when the picture practically does not change over time.

The Moving Pictures Experts Group (MPEG) was created by ISO (International Standards Organization) to develop compression standards. The MPEG-2 standard for video compression, specified by ISO/IEC 13818-2 [11] and equivalent to ITU-T H.262, was created by the MPEG group and turned out to be the *de facto* video compression standard. MPEG-2 can be used in a variety of applications, with different requirements of performance and complexity. The MPEG-2 is divided into profiles, and each profile is subdivided into levels, in a total of 24 options (not all of them are defined). Among the profiles of interest for terrestrial TV broadcast are the MP@ML (Main Profile at Main Level) and the MP@HL (Main Profile at High Level). These profiles support, respectively, the levels of resolution known as SDTV (Standard Definition Tele-Vision) – standard definition – that offers the best picture quality for transmission of conventional video, and HDTV (High Definition Tele-Vision) – high definition – used to transmit high definition picture content [14]. Although the audio compression is also defined by MPEG through the recommendation ISO/IEC 13818-3 [12], the Grand Alliance (originally formed in 1993 by AT&T, GI, MIT, Phillips, Sarnoff, Thomson and Zenith) preferred the audio compression system known as AC-3 [13]. The DVB-T uses MPEG-2 for audio compression [12].

The output of the source coding and compression subsystem contains audio or video elementary streams (ES). For practical reasons, the elementary stream is divided into packets that are called packetized elementary stream (PES). Each PES carry a unique audio or video elementary stream and contain a header with information about the identity (ID) of the sequence, size of the packet and some optional data, such as the indication of cryptography, copyright information and time stamps that are used by the receiver to learn the exact point in the time axis the packet is to be presented [15].

ITU-T H.264 [40] is among the newer video compression standards. It is equivalent to ISO/IEC 14496-10, nominally MPEG-4 Part 10. The intent of H.264/AVC project has been to create a standard that would be capable of providing good video quality at bit rates that are substantially lower (e.g., half or less) than what previous standards would need (e.g., relative to MPEG-2, H.263, or MPEG-4 Part 2). An additional goal was to do this in a flexible way that would allow the standard to be applied to a very wide variety of applications (e.g., for both low and high bit rates, and low and high resolution video) and to work well on a very wide variety of

networks and systems (e.g., for broadcast, DVD storage, RTP/IP packet networks, and ITU-T multimedia telephony systems). With higher performance of the compression stage, more spectrum will be made available for additional services like, for example, return channel services.

II.2 MULTIPLEXING AND TRANSPORT SUBSYSTEM

Multiplexing elementary streams, with or without PES packetization, creates a program transport stream² that shares a common time base. As the elementary streams are multiplexed, they are formed into transport packets, each one with 188 bytes, identified by a header field called Program ID (PID). A program transport stream contains several types of data and is identified by means of a program-mapping table (PMT), which describes what are the PIDs for audio, video and data packets corresponding to a given program. The recommendation ISO/IEC 13818-1 [10], also known as MPEG-2/SI (System Information), defines this level of multiplexing, the *system* level, that allows for the combination of several program transport streams into a unique transport stream. A new table is generated, the program association table (PAT), that contains the PMTs for all programs in the transport stream. Thus, the identification process of a program consists in two stages:

- The receiver looks for the PAT (with PID = 0), which identifies the PMT of the program chosen.
- The PIDs of the elementary streams that form the program are obtained from the PMT.

The MPEG-2 transport-stream syntax was developed for applications where channel bandwidth or recording media capacity is limited, and the requirement for an efficient transport mechanism is paramount. The MPEG-2 transport stream also was designed to facilitate interoperability with the Asynchronous Transfer Mode (ATM) transport stream [9].

II.3 TRANSMISSION / RF SUBSYSTEM

According to Figure 1, the MPEG-2 transport stream feeds the Transmission / RF subsystem. The modulation and coding used in this stage will depend on the characteristics of the medium the signal will be submitted to. TV broadcast satellite systems normally use Quaternary Phase-Shift Keying (QPSK) modulation [16]. The ITU-R J.83 [17] recommendation defines through its Annexes A, B, C e D, the transmission parameters adopted in Europe, North America, Japan and by the ATSC, respectively, for distribution via Hybrid Fiber-Coax (HFC)³ networks. Due to the controlled characteristics of these kind of networks, which do not

² A clarification on the nomenclature may be necessary at this point: the term *program stream* refers to a data stream used in applications such as DVD or in-studio connections. The program stream is not used in broadcasting systems.

³ The HFC networks are an evolution of the CATV architecture, where TV signals were distributed uniquely by means of coaxial cable. HFC networks employ a mix of optical fiber and coaxial cable for transmission.

suffer from the effects of multi-path propagation, Quadrature Amplitude Modulation (QAM) is used and covered in Annexes A, B e C. Annex D is regarded to the use of 16-VSB (Vestigial Side Band) modulation.

For terrestrial broadcast there are three standards already consolidated worldwide: the DVB-T [4] and the Integrated Services Digital Broadcasting (ISDB-T), from Europe and Japan, respectively, use the Orthogonal Frequency Division Multiplexing (OFDM) transmission technique. The modulation in the ATSC system is performed using single-carrier 8-VSB technique [18].

III. INTERACTIVITY IN DIGITAL TV SYSTEMS

The “one-way” system described so far is sufficient to provide broadcasting services. However, in order to be able to support applications like pay-per-view and Internet, a two-way link is necessary between the broadcaster and the user’s set-top box.

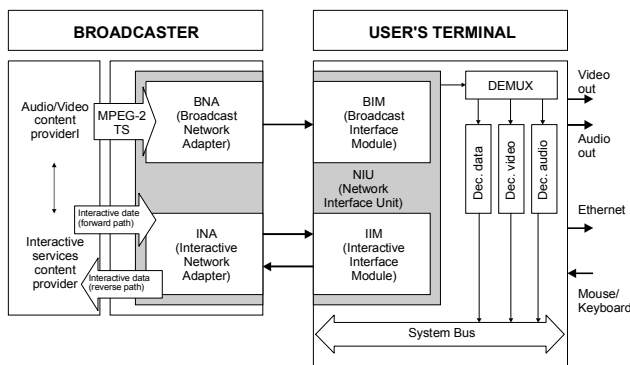

Figure 2 - A generic reference model for interactive DTV systems [1]

Figure 2 illustrates the generic model for an interactive digital TV system. Two channels are established between the broadcaster and the set-top box: the broadcast one-way channel and the interactive two-way channel. These channels can be identified in Figure 2 and are described as follows:

- **Broadcast Channel:** the audio and video content provider is equipped with coding and compression subsystems, as well as the transport service. The generated bit stream with MPEG-2 transport packets [10] feeds the Broadcast Network Adapter (BNA). This module implements the functions of the “Transmission / RF subsystem”, described in Section II. The set-top must have a Broadcast Interface Module (BIM) compatible with the BNA, so that demodulation and decoding are properly performed. At the BIM, the demultiplexer can be an Application-Specific Integrated Circuit (ASIC) that examines all PIDs of the transport stream, selects the packets corresponding to the program chosen, decrypts (if necessary) its content and sends this information to the corresponding decoders.
- **Forward interactive channel:** provides an always-on link from the broadcaster to the set-top. The

Interactive Network Adapter (INA) receives the data from the content provider and formats this data for transmission. This channel is also called Out-Of-Band (OOB) channel and is used during the authentication process with the base-station.

- **Return interactive channel:** it is the channel that allows the user to transmit information back to the broadcaster. It can be implemented using regular phone lines or by means of wireless communication.

III.1 INTERACTIVITY IN SATELLITE TV SYSTEMS

The degree of interactivity of the services offered by current Direct-To-Home (DTH) systems in Brazil is basically local. The exception to this rule is the pay-per-view service, which use the telephone line to send purchase information back to the operator. As examples, most *Sky* and *DirectTV* set-tops are now equipped with 2.4 kbit/s modems, but this rate is still very low for more advanced applications. Other systems use an uplink transmitter per user.

An advantage of satellite systems is that there is practically no restriction on geographic location for installation. The acronym DVB-RCS (Digital Video Broadcasting – Return Channel Satellite) characterizes the return channel via satellite. The physical and Medium Access Control (MAC) layers for the forward and reverse links are described in [16] and [19], respectively.

III.2 INTERACTIVITY IN CABLE TV SYSTEMS

HFC-based interactive systems normally follow the model presented in Figure 2. A portion of the spectrum is dedicated to the forward interactive channel. The return interactive channel requires that the HFC network is capable of handling bi-directional traffic. In order to do it, the available spectrum is split into two frequency bands. Typically the frequency band dedicated to the return channel is located in the lower part of the spectrum and has a bandwidth of approximately 40 MHz⁴. The forward channel goes up to 450, 550, 750 or 870 MHz, depending on the equipment used. The set-tops use the forward interactive channel for ranging procedures, which involve synchronization of the set-top with the base-station, power level adjustments and fine frequency tuning. Once on-line, these terminals can run applications whose forward data stream can also be transmitted through the broadcast channel, in a process known as *data carousel* [20]. As interactive TV applications slowly emerges on cable, subscribers from the main cities in Brazil have broadband communications available through cable modems, with rates ranging from 128 kbit/s to 512 kbit/s for domestic users.

Since CATV operator is responsible for spectrum allocation and signal content in its network, the use of a given transmission standard is not mandatory. However,

⁴ In order to cope with the demand for bandwidth, many systems currently installed deploy diplex filters with passband from 5 to 65 MHz in the return channel.

the adoption by the industry of a specified standard (of transmission, for instance) can turn out to be economically advantageous for mass production equipment, like set-tops and cable modems. An example is the Data Over Cable Service Interface Specification (DOCSIS) standard [21]. DOCSIS is largely deployed to provide broadband Internet access to cable TV subscribers. The DOCSIS project began in the U.S. in 1995 as a consortium formed at that time by the Multi-Systems Operators (MSO) Comcast, Cox, TCI and Time Warner. In 1996, version 1.0 of the radio frequency interface (RFI) was released. Version 1.1 of this RFI was issued in 1999, after CableLabs took over the project. It supports 64-QAM or 256-QAM in the forward channel, with transmission rates of 30.343 and 42.884 Mbit/s, respectively, and QPSK or 16-QAM in the return channel (with rates ranging from 0.32 to 10.24 Mbit/s).

There are two other options for standardization of the interactive channel in cable distribution systems, the ANSI/SCTE 55-1 (former DVS-178) [22] and the ANSI-SCTE 55-2 (former DVS-167) [23]. The first was developed by General Instruments (now acquired by Motorola) and issued by the Society for Cable Television Engineers (SCTE), Digital Video Systems (DVS) subcommittee. The latter encapsulates the forward data stream into MPEG-2 transport packets and transmits this stream at a rate of 2.048 Mbit/s. Messages sent through the return channel have the shape of ATM cells [24], with a 256 kbit/s transmission rate. The interactive channel employs QPSK modulation in both the direct and the return channels. The ANSI-SCTE 55-2 was submitted to SCTE by Scientific Atlanta and was extracted⁵ *verbatim* from the Digital Audio Video Council (DAVIC) standard [25]. This standard also makes use of QPSK modulation for both the downstream and the upstream. The data stream is organized in ATM cells for both the forward and the return channels.

III.3 INTERACTIVITY IN TERRESTRIAL BROADCAST TV SYSTEMS: THE DVB-RCT

One solution for implementing the return path in terrestrial TV broadcast systems is presented in the ETSI EN 301 958 standard [3], also known as DVB-RCT. The proposed interactive system consists of a forward channel compatible with DVB-T standard [4] and of a return interactive channel, which operate in different parts of the Very High Frequency / Ultra High Frequency (VHF/UHF) spectrum.

As shown in Figure 3, the forward interactive channel is embedded to the broadcast channel. The forward interactive data stream is encapsulated into MPEG-2 transport packets with specific header, multiplexed with other programs and transmitted in the same 6 MHz channel used for conventional broadcasting (analog TV systems). The transport stream sequence corresponding to

the forward interactive channel carries MAC information.

The MAC messages control user's access to the shared medium [26] and transit in both directions along the network. The difference between MAC messages in the downstream and MAC messages in the upstream is that the first ones are encapsulated into MPEG-2 transport packets, whereas the latter ones are encapsulated into ATM cells. The transmission over the physical medium of these ATM cells is carried out by means of bursts of modulated symbols, as will be seen in Section IV. The payload of each burst depends on the type of modulation and channel coding rate assigned to the terminal. Most of the MAC messages were designed to fit in the minimum payload defined for a burst. In case of contention access, when the size of the burst is smaller than an ATM cell, the MAC messages are sent directly. When the size of the burst is larger than an ATM cell, the MAC messages are encapsulated into ATM cells and then sent [3]. Data messages are always encapsulated into ATM cells before transmission.

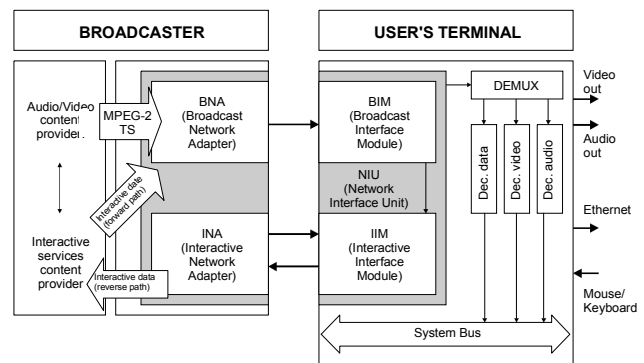

Figure 3 - A reference model for the terrestrial interactive DTV system

ATM connections allow for Quality-of-Service (QoS) provisioning, which is necessary for services employing the Voice-over-IP (VoIP) technology. The reference model for ATM protocol is divided into three layers: the ATM Adaptation Layer (AAL), ATM layer and physical layer, as shown in Figure 4.

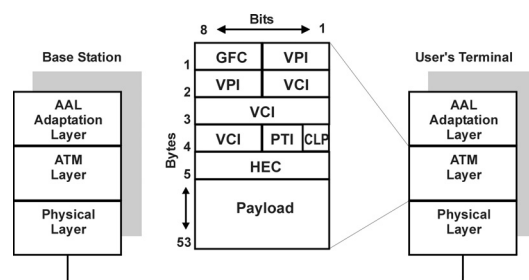

Figure 4 - ATM protocol structure [27]

The AAL layer is divided into two sub-layers: Segmentation and Reassembly (SAR) sub-layer and Convergence Sub-layer (CR). SAR sub-layer is responsible for breaking the data stream into fragments that can be accommodated in the payload of an ATM cell and for reassembling the stream from the received cells. The CS sub-layer is responsible for tasks like services

⁵ DVS-167 corresponds to Part 8 (Lower Layer Protocols and Physical Interfaces), Section 7.8 (Passband Bi-directional PHY on Coax) of DAVIC 1.2 standard [25].

multiplexing, cell loss detection and timing recovering at the destination. Four types of adaptation layers were defined, each one being capable of handling different types of services. For example, networks based on the Transfer Control Protocol / Internetworking Protocol (TCP/IP) are classified as class D and can be implemented by using ATM adaptation layer AAL-5 [27].

The ATM layer is the interface between the AAL and the physical layer. This layer is responsible for relaying cells from the AAL to the physical layer for transmission and, conversely, from the physical layer to the AAL. The header fields in an ATM cell define the functionalities of the ATM layer. The header dedicates four bits to a function called generic flow control (GFC), which was originally designed to control the amount of traffic entering the network. This allows, for example, the base-station to limit the traffic that enters the network during periods of congestion.

In order for a *switching node* to perform its function of re-transmitting the input cells to the corresponding output, it is necessary to feed the node with information about the route of the cells. The Virtual Channel Identifier (VCI), which is a single-channel identifier, together with Virtual Path Identifier (VPI) form the routing field, which associates each cell with a particular channel or circuit. The VPI allows grouping of VCs with different VCIs and allows the group to be switched together as an entity [27]. This can be imagined as if there were two layers of switching: a *lower layer*, where only the VPI is examined, and an *upper layer*, where the virtual channels from that virtual path will also be analyzed by the node when switching the input cells to the output. The Header Error Check (HEC) field is used for header error correction, whilst the Packet Type Identifier (PTI) field is used to indicate whether the cell is dedicated to transport user's data or network management information. Finally, the Cell Loss Priority (CLP) field indicates the priority in the case of a need for discarding cells.

IV. DVB-RCT PHYSICAL LAYER

IV.1 OFDM TRANSMISSION

The basic principle of OFDM multiplexing consists in transmitting data by dividing the stream into several parallel bit streams, each of which with a much lower bit rate, and by using these sub-streams to modulate several sub-carriers. Since the resulting sub-symbol has a longer duration than that of the original symbol, there will be less inter-symbol interference (ISI) due to the channel delay spread [28]. However, even with the longer duration of the transmitted symbols, some ISI can still remain; that can be resolved by using a guard interval, preferably with a duration that is longer than the *rms* delay spread caused by the channel, added to each OFDM symbol. Inter-Channel Interference (ICI) occurs when orthogonality between sub-carriers is lost at the receiver side. Practical oscillators normally have some phase modulation at their outputs, which is called *jitter*. Frequency shifts due to

phase jitter may cause ICI at the reception. The guard time also helps to combat ICI, provided that during this interval a cyclic extension of the original symbol is performed [28].

The origins of OFDM are from the mid 60's, when Chang obtained a patent [29] for a transmission structure that superimposes orthogonal modulated carriers for data transmission. The physical implementation of this technique was greatly facilitated after 1971, when Weinstein [30] introduced the idea of using the Discrete Fourier Transform (DFT) to generate OFDM signals, therefore eliminating the need for banks of analog oscillators. The construction of OFDM devices became feasible by means of algorithms that implement the Fast Fourier Transform (FFT) together with the boost experienced by the technology of Digital Signal Processors (DSPs) and programmable logic devices.

IV.2 OFDMA MULTIPLE ACCESS

The method for organizing the sharing process of the DVB-RCT channel is inspired by the DVB-T standard [4]. But, while in downstream the same MPEG-2 data packets are transmitted to all users, in the upstream a number of users need to utilize the same spectrum to transmit data back to the broadcaster or to the base-station. This demands a multiple access technique to be associated to OFDM transmission.

Since in interactive TV systems, the traffic in the return path has typically short duration, the permanent allocation of sub-carriers to a given terminal would not be efficient. DVB-RCT employs what is called Demand-Assigned Multiple Access (DAMA), which, associated to OFDM, generated the Orthogonal Frequency Division Multiple Access (OFDMA) technique. In this access rule, sub-channels are allocated to users through Medium Access Protocol (MAP) messages, which by their turn arrive to the terminal multiplexed in the program transport stream present in the broadcast channel.

A sub-channel is a set of sub-carriers out of the total available sub-carriers. In order to mitigate the frequency selective fading, the carriers of one sub-channel are spread along the channel spectrum [31]. Figure 5a shows how the frequency spectrum is organized when the total number of sub-carriers is $N = 1,024$ (1k mode). Only 841 sub-carriers are usable, because of the guard bands that are reserved at the boundaries in order to avoid adjacent channel interferences. The 841 sub-carriers are divided into $N_G = 29$ groups, each group with $N_E = 29$ sub-carriers. Some pilot carriers are also transmitted and are used for the purposes of synchronization and carriage of Channel State Information (CSI), as required by some Forward Error Correction (FEC) codes. Picking up, pseudo-randomly, one sub-carrier from each group forms one sub-channel. Therefore, in 1k mode, each sub-channel contains 29 sub-carriers. Figure 5b represents the situation for $N = 2,048$ sub-carriers (2k mode). It is noticeable from this figure that, by pseudo-randomly selecting one carrier from each subgroup, the total number of sub-

carriers per sub-channel, in this case, is 59. The user terminal receives authorization by the base-station to transmit data in one or more sub-channels, depending on the required traffic demand.

An important aspect of sub-channel utilization is related to coverage. A DVB-RCT system typically consists of a high-power transmitter installed in the base-station and a multitude of set-tops equipped with low-power transmitters. For the OFDMA option with $N = 1,024$ sub-carriers, the transmitter at the subscriber side concentrates its power into a sub-channel that has 1/29 of the channel bandwidth. For equivalent modulation and coding, this capability is directly related to the maximum coverage area.

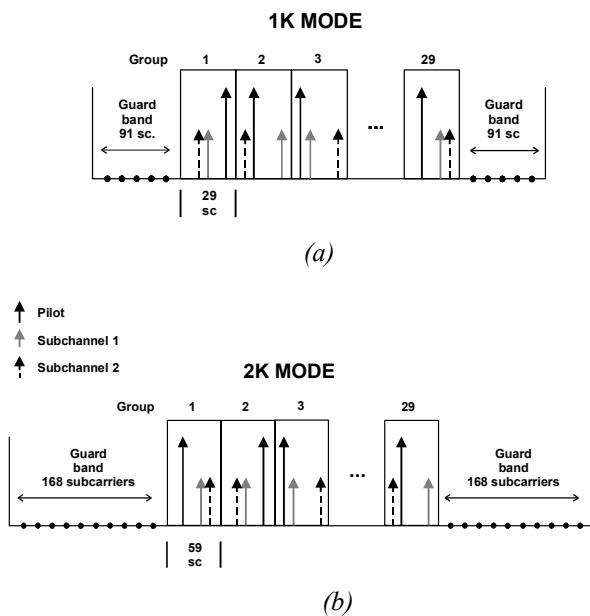

Figure 5 - Sub-channels of a system (a) DVB-RCT 1.024 and (b) 2.048 sub-carriers (DC carrier not used).

Sub-channels constitute a form of frequency hopping spread spectrum (FHSS). In every group, each set-top transmits using one pseudo-randomly selected carrier out of N_E possible ones. A terminal in an interfering cell does the same random-type selection, but in a statistically independent way. Then, the probability of collision is $1/N_E$. It is important to notice that there is no interference within the cell since its sub-channels are orthogonal: each group element is used by only one sub-channel [31].

When the input symbol stream is split in N sub-carriers, the symbol duration is augmented N times, and this tends to diminish the effects of the channel delay spread, as mentioned before. In order to provide immunity against Inter-Carrier Interference (ICI) and ISI, two types of sub-carrier shaping functions are defined:

- *Rectangular shaping*: in this case a guard interval, T_g , equal to $T_s/4$, $T_s/8$, $T_s/16$ or $T_s/32$, is included between each symbol. The total symbol duration is $T_s = T_u + T_g$, where T_u is the useful symbol duration. If the guard interval is larger than the average (rms) delay spread, the multi-path components from a given symbol will interfere less in adjacent symbols and this reduces the inter-symbol interference.

- *Nyquist shaping*: used to produce a pulse in the time domain that is associates to a root-raised cosine frequency response, with a roll-off factor $\alpha = 0.25$. The total symbol duration at the filter output is $T_s = T_u + 0.25T_u$. This type of pulse shaping yields more immunity against ICI because the resulting frequency spectrum decays more rapidly than for rectangular shaping.

In OFDMA technique, the base-station assigns to the user a fraction of the total number of available sub-carriers. The DVB-RCT transmitter module installed in the set-top must support operation using 1024 and 2048 sub-carriers, with three options for separation between sub-carriers: CS1, CS2 and CS3 (corresponding to 837, 1674 and 3348 Hz, respectively, for 6 MHz systems). Each value of sub-carrier spacing implies a given maximum transmission cell size, and a given resistance to the Doppler shift experienced when the user terminal is in motion. Table 1 shows, among other parameters, the total bandwidth occupied by the DVB-RCT channel for operation modes 1k and 2k. Once this bandwidth is taken into account for each operation mode, one could employ, in principle, any unused or partially used portion of the VHF/UHF frequency spectrum to implement the digital broadcast system's return channel.

Table 1 - DVB-RCT Transmission Modes parameters for 6 MHz DVB-T systems

| Total # of sub-carriers # of usable sub-carriers | 2048 1712 | 1024 842 |
|---|--------------|--------------|
| CS1 (sub-carrier spacing 1) | 837 Hz | 837 Hz |
| Useful symbol duration | 1195 μ s | 1195 μ s |
| DVB-RCT channel BW | 1.433 MHz | 0.705 MHz |
| CS2 (sub-carrier spacing 2) | 1674 Hz | 1674 Hz |
| Useful symbol duration | 597 μ s | 597 μ s |
| DVB-RCT channel BW | 2.866 MHz | 1.410 MHz |
| CS3 (sub-carrier spacing 3) | 3348 Hz | 3348 Hz |
| Useful symbol duration | 299 μ s | 299 μ s |
| DVB-RCT channel BW | 5.732 MHz | 5.732 MHz |

Two types of transmission frames, TF1 and TF2, are defined in order to allow synchronization at the base-station and to reserve specific symbols for ranging procedures. In TF1, three categories of symbols are defined: null symbols, ranging symbols and data symbols. As depicted in Figure 6, the sub-carriers corresponding to the first OFDM symbol of TF1 are not transmitted. This time interval can be used by the base-station to detect jammers, since all terminals of the network are synchronized and do not transmit during this time interval. The following six symbols are dedicated to ranging procedures and the remaining 176 symbols are used to transmit data.

Whereas TF1 performs the division of each symbol function in the time domain, Transmission Frame 2 structures each symbol function in the frequency domain; TF2 does not use null symbols. TF1 and TF2 frames are transmitted in bursts. Three types of burst structures are

defined, each carrying 144 symbols at the output of the modulator. Therefore, depending on the modulation used (QPSK, 16-QAM or 64-QAM) and the forward error correction code rate ($\frac{1}{2}$ ou $\frac{3}{4}$), each burst can transport a certain number of information bits. Table 2 shows the number of information bytes to be coded as a function of modulation type and code rate. The channel encoder operates with input blocks ranging from 144 to 648 bits.

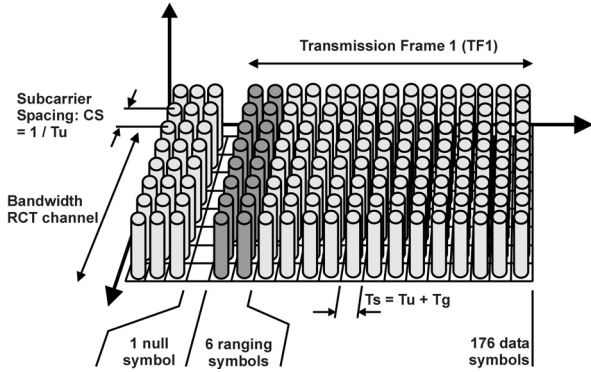

Figure 6 - DVB-RCT Transmission Frame 1.

The DVB-RCT system clock period is derived from the system clock present in the DVB-T downstream, which is defined in [4] as $7/48 \mu s$ for 6 MHz channel spacing, is defined as follows:

- Four times the DVB-T system clock period for CS1: $0.583 \mu s$;
- Twice the DVB-T system clock period for CS2: $0.292 \mu s$;
- One DVB-T system clock period for CS3: $0.146 \mu s$.

Table 2 - Number of bytes in a burst as a function of code rate and modulation type

| Modulation | Code rate | Information bytes in 144 symbols |
|------------|---------------|----------------------------------|
| QPSK | $\frac{1}{2}$ | 18 bytes |
| | $\frac{3}{4}$ | 27 bytes |
| 16-QAM | $\frac{1}{2}$ | 36 bytes |
| | $\frac{3}{4}$ | 54 bytes |
| 64-QAM | $\frac{1}{2}$ | 54 bytes |
| | $\frac{3}{4}$ | 81 bytes |

Figure 7 illustrates the block diagram of a DVB-RCT set-top box. This figure brings more details about the blocks that form the Network Interface Unit (NIU) indicated in Figure 3. The broadcast DVB-T signal goes through the duplexer and is routed to the Broadband Interface Module (BIM) in order for the original transport stream to be recovered.

The MAC management block obtains the information from the forward interactive channel by selecting the appropriate PIDs out of the received transport stream.

Still referring to Figure 7, the following characteristics of the DVB-RCT can be highlighted:

- Each DVB-RCT module transmits its information by using one or more modulated sub-carriers, with the

rate per sub-carrier depending on the transmission mode chosen by the base-station;

- The sub-carriers are synchronized by the base-station, i.e., the user terminals obtain the system timing reference from the DVB-T broadcast channel. Therefore, the transmission mode parameters employed by DVB-RCT are fixed and bear strict relationship with the DVB-T broadcast channel;
- At the base-station, the return signal is demodulated, so that at the output of the Interactive Network Adapter (INA), data coming from each user is available in the form of ATM cells.

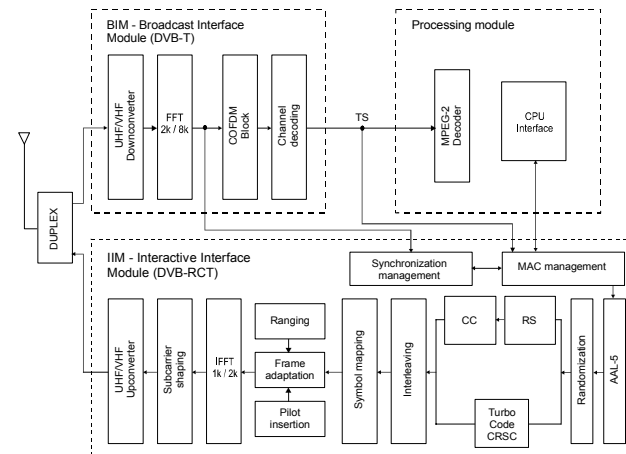

Figure 7 - Block diagram of a set-top box DVB-RCT.

The synchronization of the Interactive Interface Module (IIM) is achieved in two ways [3]: through MAC control messages received in the downstream (time-based synchronization) and through the frequency information emitted by the DVB-T modulator (frequency-based synchronization). The MAC Management and Synchronization Management blocks are responsible, respectively, for time-based and frequency-based synchronization.

The user's information is processed by the IIM, passes through the duplexer and is transmitted in the return channel using the procedures that will be described hereafter. At the base-station, the signals coming from the users are demodulated and sent to a MAC layer management block, which separates application messages (that will be routed to the respective application servers at the Interactive Services Provider) from MAC control messages, which are processed by the base-station and generate medium access information, which are then multiplexed with other programs to produce the definitive transport sequence that will be transmitted in the broadcast channel.

IV.3 RANDOMIZATION

Randomization is a technique where a shift register transforms the original data in a pseudo-random fashion. This procedure is used to insert transitions on long sequences of 0's or 1's of the original data, in such a way that the power spectrum density becomes more uniformly

distributed over the frequency spectrum. The receiver reorders the sequence using the inverse procedure, so that it gets the original data at the output. The length of the shift registers and the feedback connections generally identifies the circuits that implement the randomizer. DVB-RCT uses 15-bit shift registers and the connections are governed by the generator polynomial of the pseudo-random sequence $1 + X^{14} + X^{15}$ [3]. The bit emitted by the randomization block is applied to the channel encoder input.

IV.4 CHANNEL CODING

Channel coding is one of the key elements that define the performance of a communication system. For systems that operate with multiple carriers in multi-path environments, channel coding is even more important. The process of channel coding basically consists in adding controlled redundancy to the information. The receiver uses this redundancy to detect and/or correct errors. The code rate is defined as $r = k/n$, where k is the number of information bits and n is the number of bits at the coder output [8]. DVB-RCT establishes the following options for channel coding:

- Serial concatenation of Reed-Solomon with convolutional coding [32] [8];
- Circular Recursive Systematic Convolutional Turbo coding [33] [34].

IV.4.1 SERIAL CONCATENATION OF REED-SOLOMON WITH CONVOLUTIONAL CODE

The term *concatenation* was used by Forney [35] to designate the process of multilevel coding, formed by utilizing an *inner* code and an *outer* code (in case of serial concatenation). The inner code is normally configured to correct most of the channel errors, whereas the outer code reduces the probability of error to a specified level. The primary reason for using a concatenated code is to achieve a low error rate with an overall implementation complexity that is less than what would be required by a single coding operation [32]. For serially concatenated codes, it is possible to verify that if the inner and outer code rates are r_c and R_c , respectively, the rate of the concatenated code will be $R_{cc} = R_c r_c$. For the DVB-RCT, global code rates $1/2$ and $3/4$ are obtained from RS and convolutional codes with individual rates given by Table 3 [3].

Table 3 - Individual RS and convolutional code rates for global code rates $1/2$ and $3/4$.

| Global Code Rate | Reed-Solomon Code Rate | Convolutional Code Rate |
|------------------|------------------------|-------------------------|
| 1/2 | 3/4 | 2/3 |
| 3/4 | 9/10 | 5/6 |

A. Reed-Solomon encoding

Reed-Solomon (RS) codes are cyclic linear block codes that operate with *non-binary* symbols. The input

bits are grouped in blocks of m bits. The DVB-RCT standard defines $m = 6$, and also that the code should be able to correct up to $t = 4$ symbols in one codeword. Reed-Solomon codes are particularly useful for *burst-error correction* [32], i.e., RS codes are useful in channels that have memory. The resulting $RS(n, k, t) = RS(63, 55, 4)$ with $m = 6$ follows the conventional form of RS codes:

$$(n, k) = (2^m - 1, 2^m - 1 - 2t) = (63, 55)$$

The primitive polynomial $p(x) = 1 + x + x^6$ is used to generate the extended Galois field $GF(2^m)$. This field $GF(64)$ determines the generator polynomial $g(X) = (X + \lambda^0)(X + \lambda^1)(X + \lambda^2)...(X + \lambda^7)$, where the degree of $g(X)$ is equal to the number of parity symbols. In order to obtain the polynomial corresponding to the parity symbols during the encoding process, it is necessary (i) to shift the message vector $m(X)$ by k symbols by multiplying $m(X)$ by X^{m-k} , and (ii) to divide the result by the generator polynomial $g(X)$. The codeword at the output assumes the systematic form $RS(63, 55)$.

According to what was mentioned in Subsection IV.2, the number of information bits that are applied to the channel encoder vary in conformity with the modulation scheme and global code rate. The requirements expressed in Table 3 must be satisfied for the three types of modulation techniques and, consequently, for the different types of input block sizes. Figure 8a shows the particular case where the global code rate is $1/2$ and modulation is QPSK. From Table 2 it is seen that, in this case, 18 input bytes must be fed to the RS encoder and, since $m = 6$, this is equivalent to 24 RS symbols. Because the designed code is $RS(63, 55)$, 31 null symbols have to be appended to the 24 information symbols at the input.

The number of parity symbols remains the same 8 symbols. The resulting code rate for this $RS(36, 24)$ code is $R_c = 144/192 = 3/4$, according to what is determined by Table 3. When the required global code rate is $3/4$, DVB-RCT stipulates that only 4 out of the 8 parity symbols are sent and this is shown in Figure 8b. The codes $RS(32, 24)$ and $RS(40, 36)$ resulting from global code rates $1/2$ and $3/4$, respectively, are called *shortened codes*.

B. Convolutional encoding

The convolutional encoder responsible for generating the inner code is illustrated in Figure 9.

At each bit interval, one bit is shifted to the right in one position. The encoder memory (or *constraint length*) indicates how many shifting positions the adders operate. It is immediate to observe from Figure 9 that this code utilizes the following generator polynomials: $G_1 = 576_{oct} = 101110001_{bin}$ e $G_2 = 753_{oct} = 111101011_{bin}$. Each input bit produces two encoded bits at the output and therefore the code rate is equal to $1/2$.

Puncturing standards are defined [3] to discard certain parity bits at the transmission side, adjusting the code rate in accordance with Table 3.

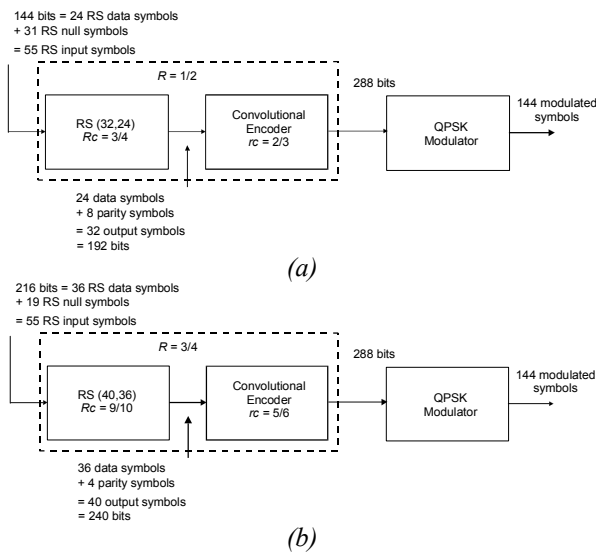

Figure 8 - Serial concatenation of Reed-Solomon with convolutional code: coding parameters for QPSK modulation with (a) code rate = 1/2; (b) code rate = 3/4.

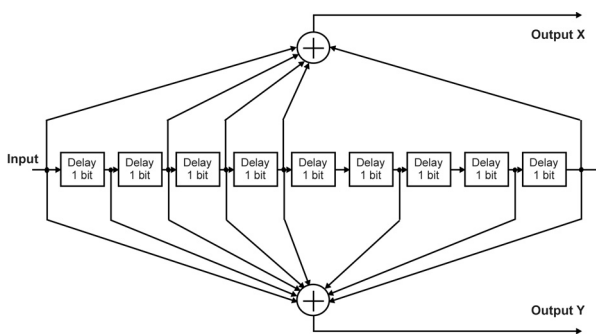

Figure 9 - Block Diagram of the convolutional encoder [3]

IV.4.2 TURBO CODE

The Circular Recursive Systematic Convolutional (CRSC) code [36], defined as one of the two alternatives for channel coding in DVB-RCT, is built from a parallel concatenation of two RSC component codes, each with two inputs. The encoder is said to be *circular* because it employs a technique in which, by the end of the encoding operation, the encoder retrieves the initial state, so that the data encoding can be represented by a circular trellis [34], dispensing the need for adding tail bits at the input for this purpose. As can be observed in Figure 10, two identical memory $v = 3$ component codes are used. The polynomial that describes the recursion is $1 + D + D^3$ and the parity bits are generated from the polynomial $1 + D^2 + D^3$. To encode the data sequence, the CRSC encoder must be fed four times, two times in normal operation mode (switch in position 1) and two times in interleaved order (switch in position 2), as shown in Figure 10. Blocks of k bits N couples ($k = 2 \times N$ bits) feed the encoder. The most significant bit of the first byte of the useful payload is assigned to input A, the next bit to input B, and so on for the remaining of the burst content. The *puncturing* patterns in order to achieve coding rates 1/2 and 3/4 are

described in [3].

An example of hardware implementation of this code is the RN-2821 modem chip [37], which has been designed specifically to operate in DVB-T / DVB-RCT systems.

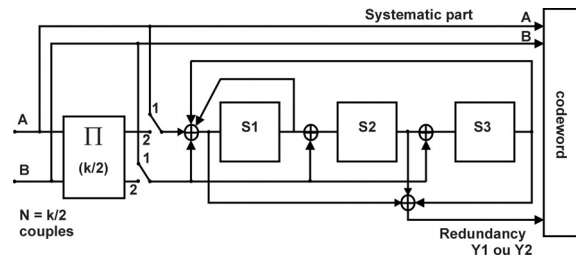

Figure 10 - Duo-binary Circular Recursive Systematic Convolutional encoder [1]

In [38], the decoding techniques *enhanced-log-APP* (EL-APP) and *enhanced-max-log-APP* (EML-APP) were proposed and compared to *log-APP* (L-APP) and *max-log-APP* (ML-APP) algorithms. The ‘max-log’ prefix indicates that those techniques use sub-optimal versions of the original algorithm and therefore are easier to implement with practical hardware.

V. DVB-RCT CELLULAR STRUCTURE

The basic configuration of a DVB-RCT cell consists of an upstream channel inside a DVB-T cell, in which the base-station typically uses an omni-directional antenna to receive the signals transmitted by the users.

There is no upstream interference within a cell since each sub-channel uses only one sub-carrier from each group at a time and the sub-carriers are orthogonal in a DVB-RCT channel. When there is re-use of frequencies in adjacent cells, the capacity supported by a cell A is determined by the interference I created by the terminals from the cells that are adjacent to cell A. To maximize this capacity the modulation schemes with the highest throughput are assigned to as many users as possible. But these schemes also have the higher C/I (signal-to-interference ratio) requirement and will transmit higher power, creating more interference. The optimal strategy is to assign the schemes with their C/I in reverse relation to the corresponding path loss, so that higher C/I schemes are assigned to terminals in location with lower path loss (generally those closer to the base-station) [31].

VI. CASE STUDY

Figure 11 depicts three possible configurations at the user’s side in a DVB-RCT system. The objective of this example is to estimate the maximum number of users that could be supported by a service provider licensed to operate a 6 MHz channel dedicated to the return path and centered at 710 MHz.

Each type of service has different traffic demands. Therefore, the first step to determine the maximum number of users in one cell is to define what kind of service will be offered. For simplicity, we will consider

that each user operates with a constant rate $R_{user} = 128$ kbit/s. Most of the interactive TV applications do not need such a rate. However, DVB-RCT could be an alternative for suburban or rural areas, where cable, ADSL or cellular coverage is not available.

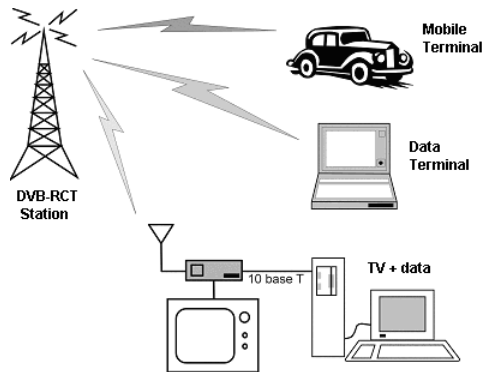

Figure 11 - Possible configurations of users in a DVB-RCT system.

In February 2002, the DVB group issued recommendation EN 301 195 [39], also known as DVB-RCG, as a ‘baseline specification for the provision of an interaction channel based on Global System for Mobile communications (GSM)’.

Another advantage of DVB-RCT over some of the aforementioned alternatives is that, once the link is established, it will be always on, with no extra costs each time the user access the medium. Therefore, besides the motivation to develop applications for interactive TV such as on-line purchase or tele-voting, the DVB-RCT could be imagined as an additional means to access the Internet. The similarities between DVB-RCT and its counterparts for satellite and cable (DVB-RCS and DVB-RCC) at the MAC and transport layers could be further studied for the sake of the design of a reference set-top box that is appropriate for the Brazilian market.

According to what was seen in Section IV.2, the maximum rate supported by a DVB-RCT channel depends on the code rate and on the type of modulation in use. The extremes are transmission modes QPSK with rate $R = 1/2$ and 64-QAM with rate $R = 3/4$. The net bit rate per sub-carrier depends also on the pulse shaping and the guard interval (for rectangular shaping). Once the net bit rate per sub-carrier is obtained, the total capacity of the DVB-RCT channel, $R_{available}$, can be computed as a function of the total number of used sub-carriers, which by its turn depends on the operation mode (see Section IV.2). Several DVB-RCT channels can be used until the whole 6 MHz of spectrum is filled. It should be clear that, if R_{user} is fixed, increasing $R_{available}$ also increases the number of subscribers that can be supported by the system.

IP traffic in the network can be highly *asymmetric*, depending on the users profile. An *Asymmetry Factor* ρ could be defined as:

$$\rho = \frac{R_{upstream}}{R_{user}} \quad (2)$$

where $R_{upstream}$ is the effective average traffic generated by the user in the upstream direction. Users that basically surf the web typically have asymmetry factor $\rho = 0.1$ (i.e., only 10% of the traffic is generated by the user). When there is a mix of e-mail, downloads and file exchanges using peer-to-peer software, the asymmetry factor goes up to 0.2 or even 0.5⁶. It is also useful to define the *Concentration Factor* γ as the relationship between N_{online} , the number of users that are on-line simultaneously, and N , the total number of users in the network.

$$\gamma = \frac{N_{online}}{N} \quad (3)$$

where $N_{online} = R_{disp} / R_{upstream}$. Without taking into consideration the IP headers, the total capacity of the system in terms of the maximum number of users can be expressed by this simple equation:

$$N_{max} = \frac{R_{available}}{\rho \cdot \gamma \cdot R_{user}} \quad (4)$$

Figure 12 shows the maximum number of users that could be supported by a cell where 30% of the users are simultaneously on-line and 25% of the traffic is generated by the user. The calculations were performed using a spreadsheet supplied by Runcom Technologies Ltd. and take into consideration the following parameters:

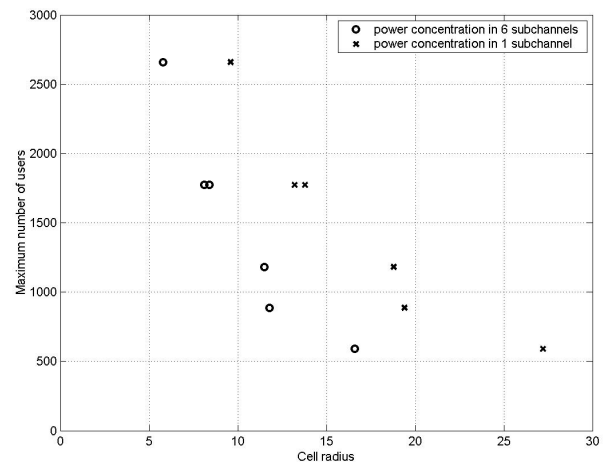

Figure 12 - Maximum number of users as a function of the cell radius (km).

- Guard interval: $T_g = 1/32 \times T_s$;
- NLOS (Non-Line-Of-Sight) propagation model;
- Transmission power at the user’s terminal: 1 W;
- Transmission power at the base-station: 100 W;
- Antenna gain at the user’s side: 18 dBi;
- Antenna gain at the base-station’s side: 18 dBi;
- Antenna height at the base-station: 50 m;
- Noise figure at the base-station receiver: 5 dB;
- Fading margin at the set-top box: 5 dB;
- Fading margin at the base-station: 5 dB.

⁶ The asymmetry factor is based on premises used by some cable operators to calculate the infrastructure needed to offer broadband connection via cable modem.

These calculations take into consideration only the traffic demand in the return channel. Since the tendency expressed by the asymmetry factor is that more throughput is required in the forward path, it is intuitive that only one 6 MHz channel may not be enough to accommodate the number of users shown in Figure 12. As an example, if 64-QAM with $\frac{3}{4}$ code rate is used in the return channel, the available rate $R_{available}$ is 25,53 Mbit/s, and this leads to a maximum number of users equal to:

$$N_{max} = \frac{25.53 \times 10^6}{0.25 \times 0.3 \times 128 \times 10^3} = 2,659$$

with a coverage radius of 9.72km if the power is concentrated in one sub-channel, as can be observed in Figure 12. A small change in Equation (4) makes it possible to calculate the rate required in the downstream to satisfy the number of users supported in the return channel.

$$N_{max} = \frac{R_{available}(downstream)}{(1-\rho) \cdot \gamma \cdot R_{user}} \quad (5)$$

Substituting the values for N_{max} , ρ and γ , yields:

$$\begin{aligned} R_{available}(downstream) &= N_{max} (1-\rho) \gamma R_{user} \\ &= 2,659 \cdot (1-0.25) \cdot 0.3 \cdot 128 \cdot 10^3 \\ &= 76.58 \text{ Mbit/s} \end{aligned}$$

Using 64-QAM and code rate $\frac{3}{4}$ in the forward DVB-T channel, the available rate is 27.14 Mbit/s and the coverage radius is 13.25 km. Therefore, if this combination is chosen at a given time, at least three 6 MHz channels would be necessary, exclusively for the forward path, to comply with the traffic demands of the 2,659 users.

VII. FINAL COMMENTS

After a short introduction on digital TV systems architectures, the physical layer of the DVB-RCT was presented. Although this system has been designed for applications with light demands for traffic, a case study investigated the capacity limits for a scenario where two 6 MHz channels were dedicated exclusively for IP-based services. The maximum number of users was calculated taking into consideration asymmetry and concentration factors. The case where the frequency is reused in adjacent cells will be covered in a forthcoming work.

The robustness of the system is important in the light of Brazilian marketplace, where more than a half of the existing TV sets receive off-air signals using internal antennas. Since 90% of the homes have at least one TV set and, up to this date, only 7% of the population have access to the internet, it seems reasonable the Government's inclination to use digital TV platform as a mechanism to stimulate what is being called digital inclusion. It might be useful, however, to broaden the

scope of the discussion about standardization to include the return channel in the list of priorities. Besides providing an overview about the possibility of implementation of a return channel, this article aims at stimulating those debates.

VIII. GLOSSARY

AAL: *ATM Adaptation Layer*
 ADSL: *Asynchronous Digital Subscriber Line*
 ANATEL: *Agência Nacional de Telecomunicações*
 APP: *A Posteriori Probability*
 ASIC: *Application-Specific Integrated Circuit*
 ATM: *Asynchronous Transfer Mode*
 ATSC: *Advanced Television Systems Committee*
 AVC: *Advanced Video Coding*
 BIM: *Broadcast Interface Module*
 BNA: *Broadcast Network Adapter*
 CLP: *Cell Loss Priority*
 CRSC: *Circular Recursive Systematic Convolutional*
 CS: *Carrier Spacing*
 CSI: *Channel State Information*
 DAMA: *Demand-Assigned Multiple Access*
 DAVIC: *Digital Audio Video Council*
 DFT: *Discrete Fourier Transform*
 DOCSIS: *Data Over Cable Interface Specification*
 DSP: *Digital Signal Processing*
 DTH: *Direct-To-Home*
 DTV: *Digital Tele-Vision*
 DVB: *Digital Video Broadcasting*
 DVB-RCC: *Digital Video Broadcasting: Return Channel-Cable*
 DVB-RCS: *Digital Video Broadcasting: Return Channel-Satellite*
 DVB-RCT: *Digital Video Broadcasting: Return Channel-Terrestrial*
 DVB-T: *Digital Video Broadcasting: Terrestrial*
 DVD: *Digital Versatile Disk*
 EL-APP: *Enhanced-Log-APP*
 EML-APP: *Enhanced-Max-Log-APP*
 EPG: *Electronic Program Guide*
 ES: *Elementary Stream*
 ETSI: *European Telecommunications Standards Institute*
 FEC: *Forward Error Correction*
 FFT: *Fast Fourier Transform*
 FHSS: *Frequency Hopping Spread Spectrum*
 GF: *Galois Field*
 GFC: *Generic Flow Control*
 GSM: *Global System for Mobile communications*
 HDTV: *High Definition Tele-Vision*
 HEC: *Header Error Check*
 HFC: *Hybrid Fiber-Coax*
 IIM: *Interactive Interface Module*
 INA: *Interactive Network Adapter*
 ISDB-T: *Integrated Services Digital Broadcast - Terrestrial*
 ICI: *Inter-Channel Interference*
 ISI: *Inter-Symbol Interference*
 ISO: *International Standards Organization*

ITU: *International Telecommunications Union*
 L-APP: *Log-APP*
 MAC: *Medium Access Control*
 MAP: *Medium Access Protocol*
 MP@HL: *Main Profile at High Level*
 MP@ML: *Main Profile at Main Level*
 MPEG: *Moving Pictures Experts Group*
 MSO: *Multi-Systems Operator*
 NIU: *Network Interface Unit*
 NLOS: *Non-Line-Of-Sight*
 OFDM: *Orthogonal Frequency Division Multiplexing*
 OFDMA: *Orthogonal Frequency Division Multiple Access*
 OOB: *Out-Of-Band*
 OS: *Operational System*
 PES: *Packetized Elementary Stream*
 PID: *Packet Identifier*
 PAT: *Program Association Table*
 PMT: *Program Map Table*
 PTI: *Packet Type Identifier*
 PVR: *Personal Video Recording*
 QAM: *Quadrature Amplitude Modulation*
 QoS: *Quality-of-Service*
 QPSK: *Quaternary Phase Shift Keying*
 RS: *Reed Solomon*
 RSC: *Recursive Systematic Convolutional*
 RTP/IP: *Real-Time Protocol / Internetworking Protocol*
 SAR: *Segmentation And Reassembly*
 SCTE: *Society for Cable Telecommunications Engineers*
 SBTVD: *Sistema Brasileiro de TV Digital*
 SDTV: *Standard Definition Tele-Vision*
 TCP/IP: *Transfer Control Protocol / Internetworking Protocol*
 TF: *Transmission Frame*
 TS: *Transport Stream*
 VC: *Virtual Channel*
 VCI: *Virtual Channel Identifier*
 VPI: *Virtual Path Identifier*
 VoIP: *Voice Over IP*
 VSB: *Vestigial Side Band*

IX. REFERENCES

- [1] BRASIL. Decreto n. 4.901, de 27 de novembro de 2003. Institui o Sistema Brasileiro de Televisão Digital – SBTVD, e dá outras providências. Atos do Poder Executivo, Brasília: Nov., 2003.
- [2] BRASIL. Exposição de Motivos do Decreto n. 4.901, de 27 de novembro de 2003. Brasília: November, 2003.
- [3] ETSI EN 301 958 V1.1.1, *Digital Video Broadcasting (DVB); Interaction channel for Digital Terrestrial Television (RCT) incorporating Multiple Access OFDM*, European Standard (Telecommunications series), Dec., 2001.
- [4] ETSI EN 300 744 V1.4.1, *Digital Video Broadcasting (DVB); Framing structure, channel coding and modulation for digital terrestrial television*, European Standard (Telecommunications series), Jan., 2001.
- [5] PREDERGAST, D.; WU, Y.; SALEHIAN, K.; GUILLET, M.; CARON, B. *Digital video broadcasting return channel terrestrial (DVB-RCT) and on channel repeaters (OCR) for broadband internet multimedia service to rural and remote access*. IBC 2004: International Broadcasting Convention, Amsterdam: Sep., 9 - 14, 2004, p. 121 – 131.
- [6] Datasheet, *Explorer® 8000HD™ Home Entertainment Server*, Scientific Atlanta Inc., Part Number: 4004400, Rev. C, Nov., 2003.
- [7] GONÇALVES, R. *Anatel e Minicom levantam bandeira da inclusão digital*. Tela Viva News. In <http://www.itweb.com.br/noticias/artigo.asp?id=47566> Accessed in Oct., 21st, 2004.
- [8] HAYKIN, S. *Communication Systems*. 4th. Ed. New York: John Wiley, 2001.
- [9] WHITAKER, J. *Standard Handbook of Video and Television Engineering*. 3rd Ed. New York: McGraw Hill, 2000.
- [10] ISO/IEC 13818-1 *MPEG-2: Systems*. International Standard, 1994.
- [11] ISO/IEC 13818-2 *MPEG-2: Video*. International Standard, 1994.
- [12] ISO/IEC 13818-3 *MPEG-2: Audio*. International Standard, 1994.
- [13] ATSC Advanced Television Systems Committee standard A/52, *Digital Audio Compression (AC-3)*, 10 Nov., 1994/12 Apr., 1995.
- [14] TEKTRONIX. *A Guide to MPEG Fundamentals and Protocol Analysis (Including DVB and ATSC)*, White Paper, 1997.
- [15] NALON, J. A.; IANO, Y. MPEG-2: Camada de Sistemas. *Telecomunicações*, v. 3, n. 1, p. 28-34, Apr., 2000.
- [16] ETSI EN 300 421. *Digital Video Broadcasting (DVB); Framing structure, channel coding and modulation for 11/12 GHz satellite services*. *European Standard (Telecommunications series)*, 2001.
- [17] ITU-T International Telecommunication Union – Recommendation J.83: *Digital Multi-Programme Systems for Television Sound and Data Services for Cable Distribution*. Oct., 1995.
- [18] ATSC Advanced Television Systems Committee standard A/53, *Digital Television Standard*. Sep., 1995.
- [19] ETSI EN 301 790 V1.3.1. *Digital Video Broadcasting (DVB); Interaction channel for satellite distribution systems*. *European Standard (Telecommunications series)*. Mar., 2003.
- [20] FARIA, G. *DVB-RCT: The Missing Link for Digital Terrestrial TV*. Harris Broadcast Europe – ITIS products.
- [21] DOCSIS, *Data Over Cable Services Interface Specifications*, in www.cablemodem.com.
- [22] ANSI/SCTE. *Digital Broadband Delivery System: Out-of-band Transport Part 1: Mode A, 55-1*. USA Standard, 2002.
- [23] ANSI/SCTE. *Digital Broadband Delivery System: Out-of-band Transport Part 2: Mode B, 55-2*. USA Standard, 2002.

- [24] SOARES, L.F.; LEMOS, G.; COLCHER, S. *Redes de Computadores; das LAN's, MAN's e WAN's às Redes ATM* – 2ª. Ed. Rio de Janeiro: Campus, 1995.
- [25] DAVIC, *Digital Audio Video Council*, in www.davic.org.
- [26] FAZEL, K.; KAISER, S. *Multi-Carrier and Spread Spectrum Systems*. New York: John Wiley, 2003.
- [27] KAI-YEUNG, S.; RAJ, J. A Brief Overview of ATM: Protocol Layers, LAN Emulation, and Traffic Management. *ACM SIGCOMM Computer Commun. Rev.*, v.25, Issue 2, p. 6-20, 1995.
- [28] VAN NEE, R.; PRASAD, R. *OFDM for Wireless Multimedia Communications*. Norwood: Artech House, 2000.
- [29] CHANG, ROBERT W., *Orthogonal Frequency Multiplex Data Transmission System*, U.S. Patent Nr. 3,488,445. 1966.
- [30] WEINSTEIN, S. B.; EBERT, P. Data Transmission by Frequency-Division Multiplexing Using the Discrete Fourier Transform. *IEEE Trans. Communication Tech.*, n. 5, p. 628 – 634. Oct., 1971.
- [31] KOFFMAN, I. Broadband Wireless Access Solutions Based on OFDM Access in IEEE 802.16. *IEEE Communications Mag.*, n. 4, p. 96 – 103. Apr., 2002.
- [32] SKLAR, B. *Digital Communications – Fundamentals and Applications*. 2 Ed. Upper Saddle River: Prentice Hall, 2001.
- [33] BERROU, C. et al. The Turbo Code Standard for DVB-RCS. *2nd International Symposium on Turbo Codes and Related Topics*: p. 535 – 538. Sep., 2000.
- [34] BERROU, C. Turbo Codes: Some Simple Ideas for Efficient Communications. *Seventh International Workshop on Digital Signal Processing Techniques for Space Communications*. Noordwijk, The Netherlands. Oct. 29-31, 2001.
- [35] FORNEY, G. D. *Concatenated Codes*. MIT Press, 1966.
- [36] BERROU, C.; JÉZÉQUEL, M. Non-binary convolutional codes for turbo coding. *Electronics Lett.* v.35, n. 1, p. 39-40. Jan., 1999.
- [37] Datasheet, *RN-2821 Typhoon*, Runcom Technologies Ltd., RN2821 02-0602, 2002.
- [38] KABAL, P.; GUINAND, P., OULD-CHEIKH-MOUHAMEDOU, Y. Enhanced Max-Log_APP and Enhanced Log-APP Decoding for DVB-RCS. *Proc. Int. Symposium on Turbo Codes and Related Topics*, p. 259 – 263. Brest, France. Sep., 2003.
- [39] ETSI EN 301 195. Digital Video Broadcasting (DVB): Interaction channel through the Global System for Mobile communications (GSM). *European Standard (Telecommunications series)*. Feb., 2002.
- [40] ITU-T International Telecommunication Union – Recommendation H.264: *Advanced Video Coding for Generic Audiovisual Services*, 2003.

ABOUT THE AUTHORS

Ângelo Pinelli Martins Samia was born in Olímpio Noronha, MG, Brazil, on September 17, 1971. He graduated in Electrical Engineering at Inatel in 1994 and obtained his Master degree in Telecommunications in 2004 at the same institution. He worked with Alcatel Telecomunicações S/A for two years in the Marketing Department and for two more years doing technical support in the PABX range of products. Ângelo was hired by Scientific Atlanta do Brasil in 1998, where he became responsible for structuring both Technical Support and Post-Sales activities for the customers in Latin America. He is currently with Tecsys Industrial do Brasil Ltda., collaborating with the Engineering team to develop solutions for digital TV processing and transmission over cable and satellite networks.

Dayan Adionel Guimarães was born in Carrancas, MG, Brazil, on March 01, 1969. He holds the titles: Doctor in Electrical Engineering (Unicamp, 2003); Master in Electrical Engineering (Unicamp, 1998); post-graduated (*lato-sensu*) in Data Communication Engineering (Inatel, 2003); post-graduated (*lato-sensu*) in Administration with emphasis in Human Resources Management (FAI, 1996) and Electronics Technician (ETE “FMC”, 1987). In former job functions Dr. Dayan developed sensors and equipment for instrumentation and control and also held the Production Supervisor and Product Engineering Supervisor positions at SENSE Sensores e Instrumentos, from 1988 to 1993. He was also responsible for the structure that supports practical teaching activities related to Telecommunications and Electronics at Inatel, an Institute of Telecommunications and Computer Engineering in Brazil, where, since 1995, his is a Professor. His research includes the general aspects of wireless communications, especially those related to Multicarrier CDMA systems and channel coding for fading channels, especially Block Turbo Codes.