

QoS in next generation Networks

Pascal Lorenz

Abstract— With the development of new multimedia applications, telecommunication networks should be developed to offer real QoS. Different protocols such as MPLS, IntServ and DiffServ introduce new mechanisms which can be used to offer QoS in future high speed networks. This paper is focused essentially on QoS mechanisms in wired and wireless networks through the presentation of new communication architectures and protocols.

Index Terms— QoS, NGN, wireless networks, protocols.

Resumo— Com o desenvolvimento de novas aplicações multimídia, as redes de telecomunicações devem ser desenvolvidas para oferecer QoS real. Diferentes protocolos tais como MPLS, IntServ e DiffServ introduzem novos mecanismos os quais podem ser usados para oferecer QoS para as futuras redes de alta velocidade. Este artigo foca essencialmente os mecanismos de QoS em redes cabeadas e sem fio através da apresentação de novas arquiteturas e protocolos de comunicação.

Palavras chave— QoS, NGN, wireless networks, protocols.

I. INTRODUCTION

To offer Quality of Service (QoS) there are a lot of parameters that should be taken into account, such as bandwidth, latency, jitter, packet loss, packet delay. A given application does not take into account all parameters with the same priority. For video applications, the most important QoS parameter is based on the bandwidth. For Voice over IP (VoIP) applications, the most important QoS parameter is based on latency with end to end delay no larger than 200 ms.

The QoS can be linked to the:

- network level: in this case the QoS depend of the network policy and of the used mechanisms such as filters, rerouting in the core of the network, control access at the corners of the network.
- application level: in this case it is the application which improve the QoS and there is no link with the network infrastructure.

The Classes of Service (CoS) classify the services in different classes and manage each type of traffic with a particular way. ETSI (European Telecommunications Standards Institute) has introduced four CoS: Class 1 for Best Effort until Class 4 for QoS guaranteed. Many SLA (Service Level Agreement) offers three CoS: Premium (for 15% of network resources), Olympic (for 80% of network resources)

Manuscript recebido em 22 de setembro de 2009; revisado em 23 de setembro de 2009.

Pascal Lorenz (lorenz@ieec.org) is from University of Haute Alsace. IUT - 34 rue du Grillenbreit 68008 Colmar – France.

and Best Effort.

Internet is increasing exponentially and the bandwidth doubles every 18 months. In 2001, there were 180 million users and today there is 1,3 billion users. 90% of the Internet traffic is based on TCP and 10% on UDP protocol (75% for WWW applications, 3% for the Emails, 4% for FTP and 7% for the News).

II. QoS MECHANISMS

There are many QoS mechanisms that can be used to offer QoS in the network. In the last years, we have observed a growth of the networks capacity with the development of Wavelength Division Multiplexing (WDM) technologies.

The different types of QoS mechanisms can:

- Provide a fair service with Best Effort algorithms.
- Maximize the bandwidth allocation to the source receiving the smallest allocation (max-min allocation of bandwidth). This algorithm allows decreasing the bandwidth allocated to other source.
- Drop the packets if congestion occurs in routers when the buffer is full (tail drop algorithm) or when the buffer occupancy increases too much (RED: Random Early Detection algorithm).
- Use congestion control mechanisms in end systems to inform the source about network congestion with ICMP or tagged packets with ECN (Explicit Congestion Notification) protocols. In this case, all routers should implement the congestion control mechanisms.
- Divide the output buffers in N queues and introduce a scheduler (processor sharing or round robin algorithms).
- Classify the IP flows at different layers: the edge routers perform classification/marketing and the backbone routers rely on marking.
- Support n drop priorities to offer a minimum bandwidth service with n RED algorithms running in parallel (weighted RED algorithm).
- Introduce a weight to each queue (Generalized Processor Sharing/Weighted Round Robin algorithms).

The new communication networks must offer QoS and mobility. The two major possibilities are:

- QoS mechanisms based on signalization and routers. It is the solution used by the telecommunication world or
- Overprovisioning the network for new applications such as TV on demand, telephony IP. Overprovisioning is not

a global solution but is an asset for traffic engineering and for QoS in Internet networks.

In the core of the network, the architectures can be based on these two following models:

- with signaling (such as the SS7, X25/ATM, Internet/Telecom networks). These networks offer good QoS but these solutions are expensive: an UMTS access point costs about 15000 \$.
- without signaling (such as the Arpanet, 1st and 2nd Internet generation networks). These networks offer no QoS but these solutions are cheap: a WiFi access point costs about 100 \$.

Initially ATM (Asynchronous Transfer Mode) was the best and unique network to offer QoS, but now ATM is less and less used. Therefore we can observe in the evolution of network architectures based on full ATM, on IP over ATM and now on full IP.

The different network architectures can be represented as follows:

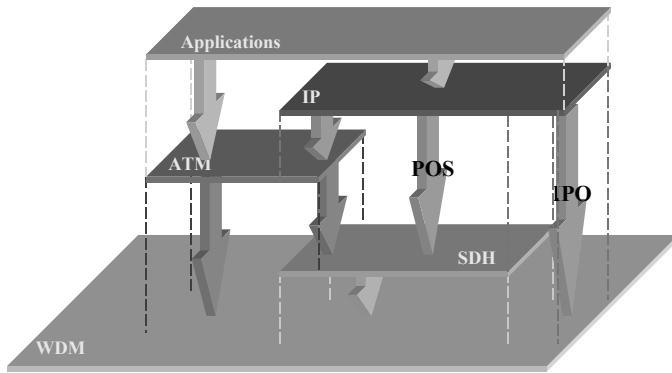

Fig. 1: Representation of the different networks architectures.

We will now present the ATM protocol that is the first protocol which offers QoS.

III. ATM PROTOCOL

ATM is a connection-oriented protocol, which offers real QoS guaranties. The QoS is negotiated during the establishment of the connection and depends of the available resources.

ATM is based on VC (Virtual Channels) and on VP (Virtual Paths). VP and the VC can be represented as follows:

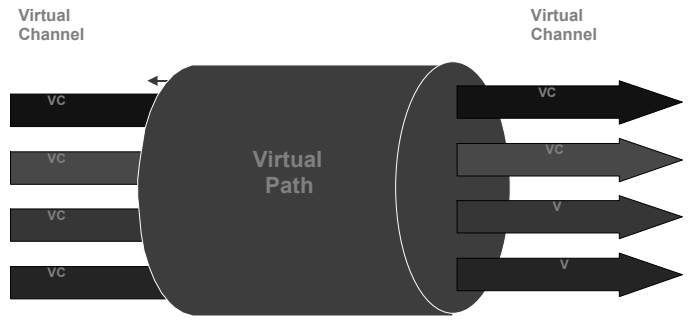

Fig. 2: Representation of VP and VC.

In ATM networks, there are six CoS:

- CBR (Constant Bit Rate), which guarantees a constant bit rate for applications such as videoconferencing, telephony.
- RT-VBR (Real-Time Variable Bit Rate) for transmissions with a variable rate for applications requiring real-time constraints, such as MPEG transmissions.
- NRT-VBR (Non-Real-Time Variable Bit Rate) for transmissions with a variable rate for applications requiring no real-time constraints, such as multimedia transfers.
- ABR (Available Bit Rate) for transmissions of traffic using the remaining bandwidth or based on bursty traffic. ABR guaranties always a minimum rate.
- GFR (Guaranteed Frame Rate) for applications, which accept to loose sometime some services.
- UBR (Unspecified Bit rate), which offer no rate guaranty and no congestion indication. UBR is a Best Effort CoS.

The representation of the different ATM CoS can be represented as follows:

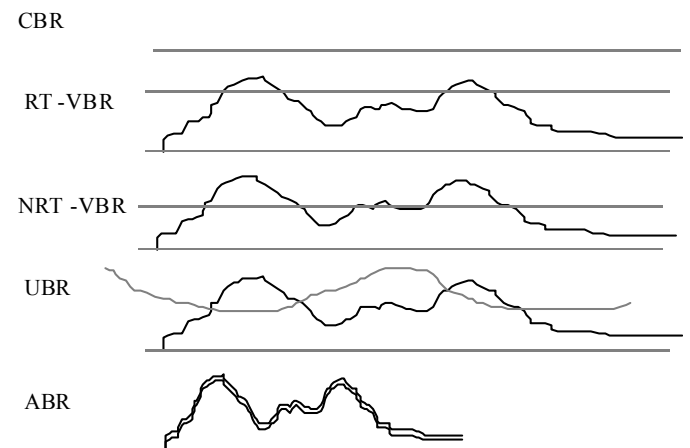

Fig. 3: Representation of the ATM CoS

For these CoS, different AAL (ATM Adaptation layer) have been defined:

- AAL1: for oriented connection and real-time traffic (CBR)

- AAL2: for variable real time traffic (VBR)
- AAL3/4: for variable real-time traffic (ABR, GFR)
- AAL5: for reliable or non-reliable services and unicast or multicast traffic (UBR).

In ATM networks, QoS is provided by the signalization and stream controls mechanisms. The major QoS parameters used by ATM networks are:

- CTD: Cell Transfer Delay
- CMR Cell Misinsertion Ratio
- CLR: Cell Loss Ratio
- CER: Cell Error Ratio
- PCR: Peak Cell Rate
- MCR: Minimum Cell Rate
- CVDT: Cell variation Delay Tolerance

- SCR: Sustainable Cell Rate
- BT: Burst Tolerance
- CDV: Cell Delay Variation

The ATM stream control mechanisms are based on:

- CAC (Connection Admission Control) that determines if a connection can be accepted or not.
- Usage Parameter Control/Network Parameter Control (UPC/NPC) that controls the traffic and the conformity of a connection.
- The Resource Management mechanisms that optimize the traffic.

An example of an ATM control mechanism can be represented as follows:

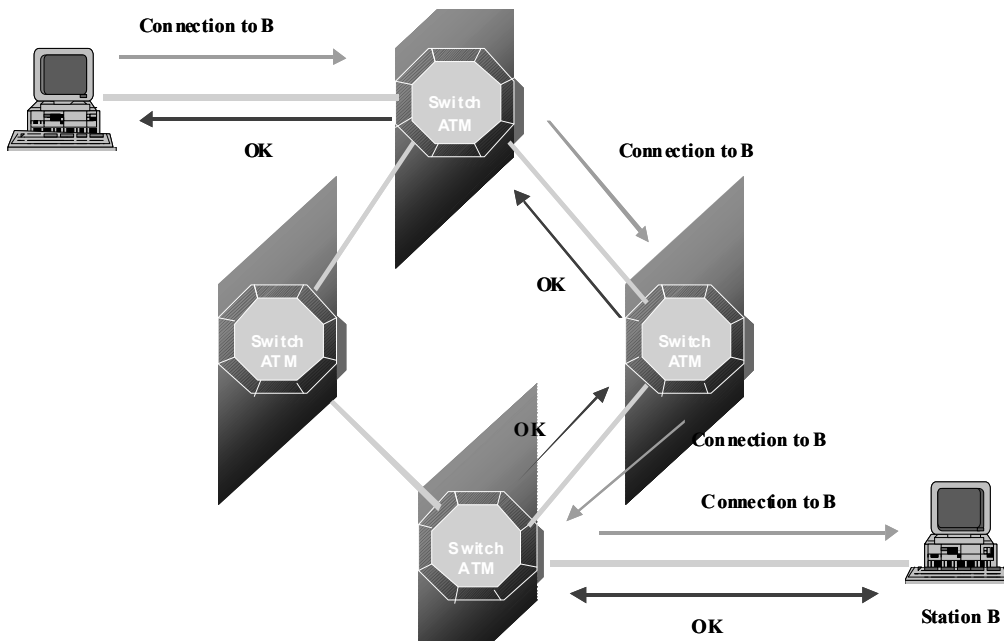

Fig. 4: ATM control mechanism

There are three major protocols used to manage IP over ATM: LAN Emulation (LANE), Classical IP and Multi Protocol Over ATM (MPOA).

MPOA is used in wide area network and avoids the router bottleneck problems thanks to the introduction of a route server for the ATM address resolution. MPOA can be considered as a virtual router, which divides data transmission from data computation functions.

A MPOA architecture can be represented as follows:

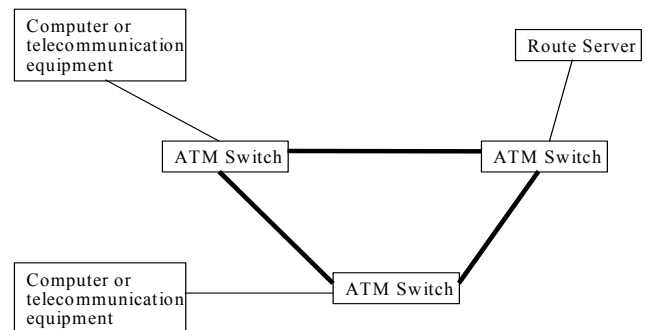

Fig. 5: MPOA architecture

The disadvantage of ATM is that there is a big overhead. ATM is also an expensive technology and the support of the IP protocol is complex.

IV. NEW COMMUNICATION ARCHITECTURES

The first mechanisms allowing QoS have been developed in 1996 with proprietary solutions such as Tag Switching (Ipsilon), IP Switching, Net Flow Switching (Cisco), ARIS (IBM), IP Navigator (Cascade), etc...

The signaling steps are separated from the data transmissions steps. The signaling management is done by the routers to offer control and management functionalities and the switches are used only for the data transmission.

The IP switching solution, represented in the following figure, is based on the separation of routing and switching functionalities:

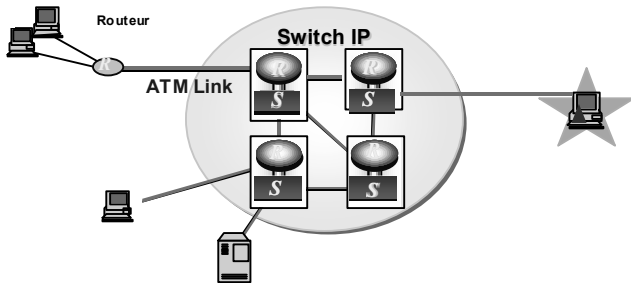

Fig. 6: IP Switching architecture

In a given communication, only the first packet is routed (if the first packet is unknown from the switch) and the other packets of the application are only switched and no more routed as represented in following Fig. 7:

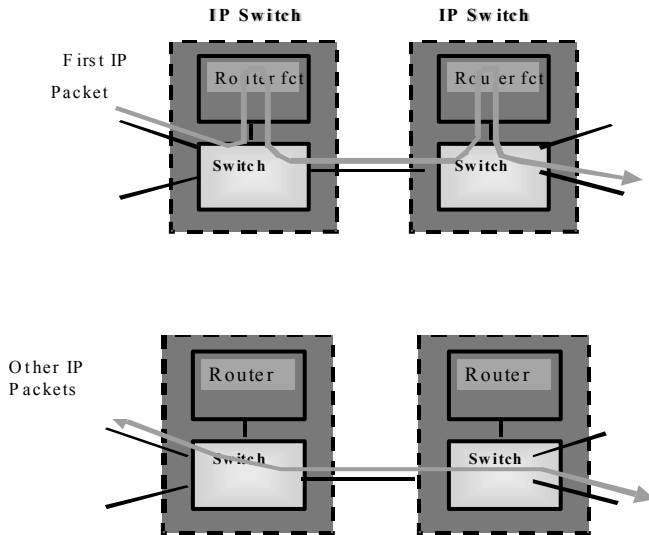

Fig. 7: Representation of IP Switch mechanisms

IP protocol is used for routing, signaling and for the switching tables management that represent 20% of the traffic. Layer 2 protocols such as ATM or Ethernet protocols are only used the fast forwarding that represent 80% of the traffic.

The different QoS mechanisms for an IP network (such as MPLS, DiffServ, IntServ, RSVP) can be represented in an OSI architecture as follows:

Transport Layer	IntServ, RSVP, DiffServ
Network Layer (IP)	MPLS
DataLink Layer (Ethernet, FR, ATM, PPP)	
Physical Layer (Sonet/SDH, optical fiber, 802.17: Resilient Packet Ring)	

Fig. 8: Description of the different IP QoS protocols

We will now describe the different IP QoS protocols MPLS, RSVP, IntServ and DiffServ.

A. MPLS (Multi Protocol Label Switching)

MPLS is based on packet forwarding. A four octets label is assigned when the packet enter into the network. The assignment of a packet to a FEC (Forwarding Equivalence Class) is done just once when the packet enters in the MPLS network at the ingress node. All packets with the same destination use a common route and at the egress node the labels are removed.

The label is inserted between the layer 2 header and the IP header. Existing protocols are extended to enable to piggyback on MPLS labels. The IP protocol is switched instead of routed and RIP, OSPF or BGP protocols can still be used.

MPLS nodes (called LSR or Label Switching Router) forward the packets based on the label value. MPLS combines L3 routing (IP) and L2 forwarding. The LSR can implement DiffServ, with a DiffServ over MPLS architecture.

A LSP (Label Switched Paths) is a sequence of routers. The signaling protocol LDP (Label Distribution Protocol) manages the information exchange between the LSR to establish a LSP and associates a FEC for each LSP. A LSR sent periodically a LDP Hello Message.

With MPLS it is possible to introduce a path protection/restoration with the introduction of an alternate route and the use of RSVP as Label Distribution Protocol. With CR-LDP (Constraint-based Routing LDP), the LSR establishes LSPs satisfying to a set of constraints. MPLS supports IP QoS models and can be used to build VPNs. It supports all types of traffic by defining a trunk for each pair of ingress/egress router.

GMPLS (Generalized MPLS) integrates ATM, Ethernet, FR, TDM, optical networks.

B. Ressource ReSerVation Protocol (RSVP)

RSVP is a signaling protocol used to establish unidirectional flows in IP networks. RSVP is used by routers to deliver QoS and to reserve resources in each node along a path. RSVP sends periodic refresh messages to maintain a state along a reserved path. A bandwidth is reserved for a given flow and requires resources reservation and releasing at regular intervals.

The establishment/maintain of unidirectional flows in IP networks is done through the PATH and RESV messages. The RSVP messages are encapsulated inside IP packets. RSVP supports MPLS, multicast and unicast traffics.

C. Integrated Services (IntServ)

IntServ is based on traffic control mechanisms and on the signalization protocol RSVP. The reservation is done at the router level. The problem is that:

- There is a poor scalability because the amount of state increases proportionally with the number of flows,
- All routers must implement RSVP,
- There is no policy for reservation control,
- Stations must support signalization.

Therefore, RSVP is only for small networks. The three CoS for IntServ are:

- Guaranteed Service (Premium service), for applications requiring fixed delay bound (CBR, RT-VBR).
- Controlled-Load Service (Olympic service) for applications requiring reliable and enhanced best-effort service (NRT-VBR, GFR, ABR).
- Null service, when there is no need of time constraints, but only a better best-effort service (UBR).

D. Differentiated Services (DiffServ)

DiffServ is a relative-priority scheme in which the IP packets are classified and marked at the network ingress to create several packet classes. The selected type of service is indicated inside each IP packet. DiffServ scalability comes from the traffic aggregation with the use of aggregate classification state in the core of the network. To share the bandwidth, DiffServ offers a hierarchy of different flows and is similar to MPLS, but more adapted for MAN.

Complex mechanisms depend of the number of services implemented in boundary nodes. SLA can be used between the client and the provider to specify for each service the amount of traffic that can be sent. The three CoS for DiffServ are:

- Expedited Forwarding (Premium service) for fixed bit rate between the source and the destination (CBR, RT-VBR).
- Assured Forwarding (Olympic service) for bursty services. There is no QoS guaranteed but only a low loss probability (ABR, GFR, nrt-VBR).
- Bulk Handling for applications requiring no QoS such as file transfer or mail (UBR).

E. Conclusion

The integration of QoS mechanisms is easier in small networks, because large networks ingrate a lot of heterogeneous domains.

DiffServ is less complex and easier to be implemented than IntServ, but it gives less accurately and less QoS flow

differentiation. DiffServ is located in the core of the network between the routers and IntServ at the periphery of the networks.

IntServ works on micro-flows, it is a complex technology based on a "hard" approach of QoS. In DiffServ the load control is done at aggregate level by the network and not at flow level by TCP. MPLS is another evolution of IP service: it is a generic connection orientation that increases of routing functionalities.

To summarize, in the LANs it is IntServ offers the best approach, in MANs it is DiffServ (or IntServ) and in the WANs it is MPLS.

V. QOS IN WIRELESS NETWORKS

There are many different types of wireless networks: cellular networks, mobile networks, data transmission networks and satellites networks.

For example, the wave radio-electrical networks penetrate the buildings and can be used for large distances. The wave infrared networks are used for small distance and do not penetrate the buildings. The micro-wave frequency networks do not penetrate the buildings and are used for networks no larger than 80 km. Light wave networks are based on lasers that are quickly absorbed by the rain or the snow.

In wireless terminals, some problems begin to be solved to offer a better management of the duration of the batteries (via hydrogen and supercondensator batteries), the screens (via OLED-Flexible Organic Light Emitting Diode screens) and keyboard (via laser keyboard). These different solutions are represented in the Fig. 9:



Fig. 9: OLED and laser keyboard

There are multiple access techniques: FDMA (Frequency Division Multiple Access) developed for analogical networks, TDMA (Time Division Multiple Access) developed for numerical networks, CDMA (Code Division Multiple Access) developed for third generation networks and OFDM (Orthogonal Frequency Division Multiplexing) developed for the four generation networks

A. Satellites

There are three types of satellites:

- LEO (Low Earth Orbit),
- MEO (Medium Earth Orbit),
- GEO (Geostationary Earth Orbit).

The frequencies used by the satellites use:

- Ku band (10 GHz to 18 GHz),
- C band (4 GHz to 6 GHz) for the connections between terrestrial stations and satellites,
- Ka band (20 GHz to 30 GHz).
- V band (40 GHz to 50 GHz) for future applications.

The LEO satellites are located between 500 and 2000 km. The communication delays are 0.01 second and the maximum rate is 155 Mbit/s. To cover the world 50 satellites are necessary and one satellite covers the skyline during 15 minutes. LEO based on 800 MHz, offer a 300 kbit/s rate and can be used for localization such as the GPS (Global Positioning System) system. LEO based on 2 GHz, offer a 10 kbit/s rate are used essentially for telephony applications. LEO based on 20 GHz to 30 GHz, offer 155 Mbit/s rate for multimedia applications.

MEO satellites are located at an altitude between 5000 km and 20000 km for communication delays of 0.1 second. A communication can remain one hour and 12 satellites are necessary to cover the earth.

GEO satellites are located at an altitude of 36600 km with communication delays of 0.27 second. The duration of GEO satellites are between 15 and 20 years and three satellites can cover the world.

Today, we can observe the development of pico-satellite (1 kilo) located at an altitude of 340 km and of HAPs (High Altitude Platforms).

B. 2G to 3G networks

In this section, we will present quickly the second generation (2G) and the third generation (3G) wireless networks.

The pico-cells are used for distances between 5 and 50 meters, the micro-cells for distances between 50 and 500 meters and the macro-cells for distances between 0.5 and 10 km.

In wireless networks, the Public Land Mobile Network (PLMN) is composed by the:

- Base Station Subsystem (BSS) that manage radio resources with the:
 - Mobile Station,
 - Base Transceiver Station (BTS),
 - Base Station Controller (BSC).
- Network and Switching Subsystem (NSS) that manage network resources with the:
 - Visitor Location Register (VLR) for mobiles localization,
 - Home Location Register (HLR) that contain subscription information,

- Mobile Switching Center (MSC).

- Operation Sub-System (OSS) for the administration and management of the network.

The BSC establishes the communications with the Mobile services Switching Center (MSC). When the best BTS is selected, the mobile asks for a logical signaling channel to the BSC, which manages the communications synchronization.

The 2G are based on 900, 1800 and 1900 MHz frequencies and offer a 10 kbit/s transmission rate.

GPRS (General Packet Radio Service) is a 2.5G network that offers a maximum rate of 48 kbit/s. It is based on packet switching; the cost of the communication depends only of the amount of data and not the duration of the communication. The evolution of a 2G network to a 2.5G network can be done without modification of the BSS, because 2.5G networks use the same frequency and can reuse the BTSs and the BSCs.

In GPRS networks, there is a need of two additional routers: SGSN (Serving GPRS Support Node) for the resources, sessions, taxation and mobility management and GGSN (Gateway GPRS Service Node) for IP networks interconnections.

EDGE (Enhanced Data rate for GSM Evolution) is a 2.75G network that will offer a 150 kbit/s rate. E-GPRS (Enhanced GPRS) apply EDGE to GPRS to offer similar services than UMTS (Universal Mobile Telecommunication System).

IMT2000 (International Mobile Telecommunication 2000) is essentially composed by UMTS and CDMA2000 systems. UMTS (Universal Mobile Telecommunication System) is based on 3GPP (Third Generation Partnership Project). CDMA 2000 is an American evolution of the IS-95 standard.

3G networks integrate in a same network, cellular network, wireless network, data transmission network, intelligent terminals and multimedia services such as bandwidth on demand. 3G networks are based on 1885 MHz to 2200 MHz frequencies and offer a 384 kbit/s transmission rate.

3.5G networks are based on HSDPA (High Speed Downlink Packet Access) which offers a 1Mbit/s transmission rate.

3.75G networks are based on HSUPA (High-Speed Uplink Packet Access) which offers a 4 Mb/s transmission rate.

4G networks will be based on the 30 GHz frequency and will offer 300 Mb/s transmission rate.

C. Wireless Personal Area Networks (WPAN) - IEEE 802.15

WPAN networks are composed by a lot of different versions of IEEE 802.15. The majors IEEE 802.15 standards are:

- IEEE 802.15.1: Bluetooth WPAN has a rate of 1 Mbit/s and use the 2400 MHz frequency in a 10 meters diameter around the access point.
- IEEE 802.15.3: Ultra WideBand (UWB) is a wireless technology for transmitting digital data over a wide spectrum of frequency with very low power and with a 400 Mbit/s transmission rate.
- IEEE 802.15.4: standard developed for the communications between toys and sensors (ZigBee) with

a 200 kbit/s transmission rate.

D. Wireless LAN (WLAN) - IEEE 802.11

WLAN networks are composed by different versions of IEEE 802.11 standards. The majors IEEE 802.11 standards are:

- IEEE 802.11b (WiFi – Wireless Fidelity): frequency of 2.4 GHz, transmission rate of 11 Mbit/s over 100 meters. This protocol is based on CDMA/CA.
- IEEE 802.11g: frequency of 2.4 GHz and a transmission rate of 54 Mbit/s.
- IEEE 802.11a (WiFi 5): frequency of 5 GHz and a transmission rate of 54 Mbit/s.
- IEEE 802.11i: developed to manage security aspects via EAP, WEP, TKIP, WPA.
- IEEE 802.11e: developed to manage QoS aspects.
- IEEE 802.11f: developed to manage handover aspects.
- IEEE 802.11n: based on power control offer a transmission rate of 400 Mbit/s.

WiGig (Wireless Gigabit Alliance) based on 57/66 GHz frequencies will offer a transmission rate of 6 Gbit/s.

E. WMAN (Wireless Metropolitan Area Network) IEEE 802.16

The major protocol WiMax is based on 10/66 GHz frequencies and offer a transmission rate of 120 Mbit/s over 50 km. WiMax-Mobile (IEEE 802) is based on the 3,5 GHz frequency can offer a transmission rate of 1Mbit/s for mobile station moving at a speed of 250 km/h.

The others IEEE 802.16 standards are LMDS (Local Multi-point Distribution Service) and MMDS (Multi-channel Multi-point Distribution Service).

VI. CONCLUSION

There are a lot of networks, each network offer different types of QoS based on a specific protocol. The required QoS and the price of the communication should be taken into account to decide what the best wireless network at the given location. For example, if the cheaper network WiFi is not available or does not offer enough QoS, we can to try to connect to WiMax. And if WiMax is not available, another more expansive solution can be to choose 3G or 4G networks.

The 2G GSM standard was initially based on ISDN, GPRS standard on Frame Relay and UMTS standard on ATM/AAL2 protocol. Now, the second generation of UMTS and CDMA2000 standards are based on IP protocol, which is the

now the major protocol to offer QoS in wired and wireless networks.

VII. REFERENCES

- [1] Alejandro Martínez Vicente, Georgios Apostolopoulos, Francisco J. Alfaro, Jose L. Sánchez, Jose Duato, Efficient Deadline-Based QoS Algorithms for High-Performance Networks, IEEE Transactions on Computers, July 2008, pp. 928-939
- [2] Bader Al-Manthari , Hossam Hassanein , Najah Abu Ali , Nidal Nasser, Fair Class-Based Downlink Scheduling with Revenue Considerations in Next Generation Broadband Wireless Access Systems, IEEE Transactions on Mobile Computing, June 2009, pp. 721-734
- [3] Blanca Caminero , Carmen Carrion , Francisco J. Quiles , Jose Duato , Sudhakar Yalamanchili, Traffic Scheduling Solutions with QoS Support for an Input-Buffered MultiMedia Router, IEEE Transactions on Parallel and Distributed Systems, November 2005, pp. 1009-1021
- [4] Eun-Chan Park, Efficient Uplink Bandwidth Request with Delay Regulation for Real-Time Service in Mobile WiMax Networks, IEEE Transactions on Mobile Computing, September 2009, pp. 1235-1249
- [5] H. Anthony Chan, Robert Achieng, A QoS enabling queuing scheme for 4G wireless access networks, Proceeding of the 2006 international conference on Communications and mobile computing, IWCMC '06, July 2006, pp. 1235-1240
- [6] Long Le , Ekram Hossain, Tandem Queue Models with Applications to QoS Routing, Multihop Wireless Networks, IEEE Transactions on Mobile Computing, August 2008, pp. 1025-1040
- [7] Soohong Park , Seong-Ho Jeong, Mobile IPTV: Approaches, Challenges, Standards, and QoS Support, IEEE Internet Computing, May 2009, pp. 23-31
- [8] Suresh Singh , Tom Shrimpton, Verifying Delivered QoS in Multihop Wireless Networks, IEEE Transactions on Mobile Computing, December 2007, pp. 1370-1383.

Pascal Lorenz received his M.Sc. (1990) and Ph.D. (1994) from the University of Nancy, France. Between 1990 and 1995 he was a research engineer at WorldFIP Europe and at Alcatel-Alsthom. He is a professor at the University of Haute-Alsace, France, since 1995. His research interests include QoS, wireless networks and high-speed networks. He is the author/co-author of 3 books, 2 patents and 190 international publications in journals and conferences. He was Technical Editor of the IEEE Communications Magazine Editorial Board (2000-2006), current Chair of Vertical Issues in Communication Systems Technical Committee Cluster, Chair of the Communications Systems Integration and Modelling Technical Committee and Vice Chair of the Communications Software Technical Committee. He has been Co-Program Chair of ICC'04 and symposium Co-Chair at Globecom 2009-2007 and ICC 2009-2008. He has served as Co-Guest Editor for special issues of IEEE Communications Magazine, Networks Magazine, Wireless Communications Magazine, Telecommunications Systems and LNCS. He is senior member of the IEEE, IARIA Fellow and member of many international program committees. He has organized many conferences, chaired several technical sessions and gave tutorials at major international conferences.

